



# European Journal of Educational Research

Volume 13, Issue 4, 1573 - 1585.

ISSN: 2165-8714

<https://www.eu-jer.com/>

## The Mediating Effect of Teachers' Collective Innovativeness Between School Climate and Job Satisfaction

Beibei Hu 

Zibo Normal College, CHINA

Kyung Hee Park\* 

Woosuk University, SOUTH KOREA

Zhenxia Xu 

Zibo Normal College, CHINA

Received: February 23, 2024 • Revised: April 10, 2023 • Accepted: May 6, 2024

**Abstract:** Since psychological satisfaction is influenced by the interaction between individuals and their environment, it is necessary to create a cooperative climate at the organizational level and strengthen collective innovativeness at the individual level to improve teachers' job satisfaction. Therefore, the study investigated whether collective innovativeness can be mediated by the school climate to enhance teacher job satisfaction. This study extensively examined survey data with a sample of 3,976 teachers in Shanghai through Structural Equation Modeling, obtained from Teaching and Learning International Survey (TALIS). The findings revealed that teachers' collective innovativeness served as a significant mediator between school climate and job satisfaction. Furthermore, higher levels of collective innovativeness among teachers amplified the influence of school climate on their job satisfaction. These findings show that schools should strive to foster a collaborative school climate and provide support for teachers in implementing innovative and collaborative teaching activities with the aim of enhancing their job satisfaction. Above all, efforts are needed to support teachers' active and cooperative practice capabilities in building teacher-student relationships.

**Keywords:** *Teacher, collective innovativeness, school climate, job satisfaction, teaching and learning international survey.*

**To cite this article:** Hu, B., Park, K. H., & Xu, Z. (2024). The mediating effect of teachers' collective innovativeness between school climate and job satisfaction. *European Journal of Educational Research*, 13(4), 1573-1585. <https://doi.org/10.12973/eu-jer.13.4.1573>

### Introduction

Teachers have consistently been a pivotal topic in educational research, as they can impart positive and meaningful influences on students (Coleman, 1966; Darling-Hammond, 2000). Especially, teachers' job satisfaction also spreads emotionally to students and is a crucial indicator of measuring their well-being (Caprara et al., 2006; Judge et al., 2001).

The impact that teachers have on students includes the transmission of students' emotions. Improving teachers' professional satisfaction can enhance their sense of happiness, which in turn can positively affect both their own emotions and those of their students (Burić & Moè, 2020; Laybourn et al., 2019).

Psychological perspectives and factors were the main focus for analyzing the influence of teachers' job satisfaction in most of the previous studies (Aldridge & Fraser, 2016; Caprara et al., 2006). Furthermore, subjective elements such as the conduct of school principals and the prevailing school climate, reflecting the institutional ethos, have undergone scrutiny in relation to teachers' contentment with their profession (Banerjee et al., 2017; Blömeke et al., 2021; Wang & Degol, 2016). Prior research has already underscored the potential impact of the educational environment on teachers' overall job contentment (Dou et al., 2017).

Meanwhile, in the rapidly evolving Education 4.0 era, educational models are undergoing significant transformations. A pertinent example is provided by the Organisation for Economic Co-operation and Development (OECD), in their 2019 report titled <Future of education and skills 2030>. This report highlights 'Transformative competencies' identifying three fundamental competencies essential for students to excel, engage effectively with their environment, and contribute to a global future. Of these, the first competency, 'Creating new value,' is particularly relevant to our study's focus. As described by the OECD, this competency centers on developing innovative solutions that enhance societal well-being and satisfaction.

How to cultivate students' ability to "create new value" poses new challenges to current schools and teachers. To achieve this goal, teachers ought to be innovative, including collaborative and cooperative efforts among educational institutions and colleagues (Gkorezis, 2016). These abilities are crucial for teachers to cope with contemporary challenges. Teachers'

\* **Corresponding author:**

Kyung Hee Park, Woosuk University, Wanju, South Korea. ✉ [khpark@woosuk.ac.kr](mailto:khpark@woosuk.ac.kr)



collective innovation ability not only refers to guiding students to acquire skills that create new value but is also a key factor in promoting school innovation (Thurlings et al., 2015). Teachers' collective innovation is implemented in schools, and during the implementation process, it will also have a certain impact on teachers' job satisfaction. We explore how to effectively integrate "collective innovation" capabilities into the school environment to create a more positive school atmosphere and improve teachers' job satisfaction. Nonetheless, few studies have been conducted concerning the impact of enhancing collective teacher innovation on job satisfaction, as well as its potential to foster teachers' progress and development.

Hence, this research aims to investigate how collective innovativeness performs as a mediating factor among teachers in China, establishing a link between school climate and job contentment. The aim of its research is to enhance knowledge base in educational management and teacher development through valuable contributions. Additionally, its goal is to provide valuable viewpoints and insights for the academic community, particularly in the domain of research concerning teachers' job satisfaction and school climate. This research presents the subsequent questions:

1. Is there a significant positive relationship between school climate and teacher's job satisfaction?
2. Does school climate influence teacher's job satisfaction through the mediating effect of collective innovativeness?

## Literature Review

### *Collective Innovativeness*

In order to enable students to attain or strengthen to 'Creating new value' within transformative competencies, teachers have to elevate their own capacity for creating new value, referred to as teacher innovativeness. Teacher innovativeness, essential for this endeavor, is delineated as the capability of teachers to demonstrate receptivity, openness, and a propensity to wholeheartedly welcome change (Fullan, 2015; Goldsmith, 1986).

It is considered to be the degree of teacher competence and ability to change and is a vital contributor to improving teacher performance, student academic achievement, and organizational development (McGeown, 1980). Specifically, teacher innovation requires the development of new teaching or evaluation methods or strategies to improve the quality of teaching, and these innovative ideas may originate from the education department, school administrators, or teachers themselves.

Regarding innovativeness, the notion of collective innovativeness stands as a cornerstone in equipping individuals to confront the exigencies of the 21st century and empowering them to actively participate in crafting a global landscape that advances well-being and sustainability for themselves, their peers, and the environment (OECD, 2019a).

Innovation is the use of new ideas, new methods and new practices in school teaching and learning. From this definition we can better understand the innovative practices teachers and teacher collectives implement in their settings (Tang, 2021).

The Teaching and Learning International Survey (TALIS) report conceptually termed the group-level teacher innovativeness as "Team Innovativeness," further emphasizing the collective nature of teachers (OECD, 2019b). Consequently, within the framework of TALIS's team innovativeness, the sub-elements encompassed 'generating novel concepts for pedagogy', 'embracing change', 'exploring fresh avenues to resolve challenges', and 'rendering tangible assistance to peers in the implementation of innovative concepts. There are studies that define "Team Innovativeness" as "Teacher Innovativeness" (Q. Lin, 2022; Tang, 2021), and others define it as "Collective Innovativeness" (Buyukgoze et al., 2022; Nguyen et al., 2021).

Recent research trends highlight an emphasis on the group-level teacher innovativeness, extending beyond individual teachers or small groups, encompassing the innovativeness of all teachers within a school. It extends beyond the scope of individual considerations, demanding an exploration of teacher innovativeness from both a comprehensive and collective viewpoint (Buyukgoze et al., 2022; McGeown, 1979; Moolenaar et al., 2014). Building on these assertions, there is an increasing recognition of the significance of collective teacher innovation, as it is pivotal for the initiation, sustenance, and propagation of school-level innovations (Moolenaar et al., 2014; Schwabsky et al., 2020).

Nguyen et al. (2021) demonstrated the importance of a positive school culture in promoting team innovativeness. Their study revealed that collaborative school culture had a much greater impact on teachers' innovativeness than teacher autonomy. This finding highlights the significance of teacher collaboration in promoting innovation in schools. This finding highlights the significance of teacher collaboration in promoting innovation in schools. Although collaborative school culture and teacher autonomy in the classroom are positively related, the impact of teacher autonomy on team innovativeness is less significant than the development of mutual respect, support, and vulnerability (Nguyen et al., 2021).

### *School Climate*

'School climate' denotes comprehensive sociocultural, emotional, and physical ambiance prevailing within an educational establishment. It comprises the attitudes, norms, and values that shape interactions and experiences within the student, teacher, and staff community. A favorable school climate cultivates a nurturing, all-encompassing, and captivating educational atmosphere, which positively impacts the overall welfare and scholastic achievements of both students and educators (Wang & Degol, 2016).

Creemers (1999) put forth a comprehensive framework involving various components within the concept of school climate. These include the school's physical infrastructure, which encompasses buildings and corridors, as well as the social interactions involving relationships and engagements among individuals within the school. Furthermore, the model encompasses a well-structured school environment and the anticipated standards that define teacher conduct and student accomplishments. By grasping the concept and evaluating the framework developed by Creemers, one can identify elements such as teacher-student relationships, peer collaboration, and the general working environment that are covered by this notion.

Prior research has underscored considerable influence of the school climate's influence on students' academic achievements (Izaguirre et al., 2023) and significant effects on teacher outcomes, including attrition (Djonko-Moore, 2016), effectiveness (Hosford & O'Sullivan, 2016; Meristo & Eisenschmidt, 2014), jobs satisfaction, and emotional well-being (Yang et al., 2022). Nevertheless, the comprehension of teachers' perception of the educational environment is still constrained, primarily because existing research predominantly focuses on students (Wang & Degol, 2016).

### *Teacher-Student Relationship*

The term 'teacher-student relationship' pertains to the caliber of interactions and bonds forged between educators and pupils. It encompasses elements such as trust, esteem, and proficient communication, alongside a nurturing and benevolent rapport. The presence of affirmative teacher-student relationships has been linked to heightened student involvement, scholastic drive, and comprehensive welfare.

The exploration of teacher-student relationships has drawn heavily from concepts originating in accordance with self-determination concept (Ryan & Deci, 2000) and has provided a strong theoretical basis for analysis (Wentzel, 2016). Building upon these frameworks, students are more likely to connect and develop inclination with teachers when they experience fairness and receive positive emotions (including empathy, warmth, and motivation), as well as practical assistance (such as tangible help for learning) from their educators. Teacher-student relationships marked by emotional proximity and support yield positive effects on both academic and psychological outcomes among students, supported by substantial empirical evidence.

Global research has unequivocally established the link between teacher-student interactions and student behavior on an international scale. (Aldrup et al., 2022; Wanders et al., 2020). Intimate teacher-student relationship has the potential to improve student adaptation (Hamre et al., 2008) and potentially reduce instances of problematic student behavior (Domínguez et al., 2011). Conversely, discord in teacher-student relationships could amplify behavioral challenges (Buyse et al., 2008).

### *Cooperation of Colleague*

At the school level, there has been an enhanced awareness among teachers regarding professional development. Teachers collaborate within the school environment to advance their knowledge and understanding (Borko, 2004; Kemmis et al., 2013).

Teacher collaboration hinges on the bedrock of proficient professional development. Teacher cohorts, comprising a compact assembly of educators engaged in the joint pursuit of teaching and learning, have gained escalating acceptance and are recognized as among the most influential methods for fostering advancement and expansion (Lipscombe et al., 2020).

Colleague cooperation pertains to the collaborative and mutually supportive interactions among teachers within the school environment. It involves working together, sharing ideas, and assisting one another in professional development and teaching practices. A high level of cooperation among colleagues contributes to a positive working atmosphere and can potentially influence teachers' job satisfaction (Banerjee et al., 2017).

A positive school climate that encourages collaboration and a sense of community among teachers can foster a higher level of cooperation among colleagues. Teachers who engage in effective cooperation with their colleagues may also be better equipped to develop positive relationships with their students, as collaboration among colleagues can influence instructional practices and student support. A supportive and collaborative atmosphere among colleagues is likely to enhance teachers' job satisfaction, as educators feel appreciated and bolstered in their professional capacities.

### Working Atmosphere

Working atmosphere refers to the overall ambiance and culture perceived by teachers in their workplace, encompassing factors like management style and work-related stress. This concept is closely related to school climate, as described by Mayes et al. (2020), which significantly influences teachers' work experiences and job satisfaction (Hoque et al., 2023; Toropova et al., 2021).

The research by Wang and Degol (2016) provides in-depth insights into how a positive working atmosphere contributes to fostering teacher cooperation and support within a constructive school climate. A positive working atmosphere typically promotes collaboration and support among teachers, encouraging them to collectively solve problems and share teaching experiences. The influence of school administrators' behavior and the school climate on teacher-student relationships is further supported by the findings of Şahin and Tabak (2020).

A positive working atmosphere is often linked to higher levels of teacher job satisfaction. The organizational climate, as Khan (2019) notes, plays a crucial role in influencing teachers' commitment, which in turn affects their job satisfaction and long-term retention intentions (Hoque et al., 2023; Toropova et al., 2021).

### Teachers' Job Satisfaction

Teacher job satisfaction encompasses a multifaceted concept rooted in the research of Herzberg (1993). Existing research commonly interprets job satisfaction as individuals' affirmative or negative evaluations of their occupation. Prior studies have already demonstrated a link between teachers' job satisfaction and a range of outcomes, including enthusiasm (Weiqi, 2007), commitment (Reyes & Shin, 1995), job performance (Judge et al., 2001), burnout (Skaalvik & Skaalvik, 2010), teacher retention (Schaufeli & Salanova, 2007), also, the way educators perceive their dedication to engaging with students and their overall duties (Caprara et al., 2006; Dinc & Kocyigit, 2017; Gokalp, 2022; Mailool et al., 2020; Sukarmin & Sin, 2021; Uwannah et al., 2022).

Our analysis of previously conducted studies has comprehensively uncovered a range of factors influencing job satisfaction. Empirical findings indicate a notable influence of school climate on teachers' job satisfaction. For instance, prior research has established connections between job satisfaction and various aspects, including positive teacher-student relationships (Dinham, 1995), involvement in decision-making processes and the existence of transformative leadership (Bogler, 2001; Rossmiller, 1992), as well as interactions with colleague members. A positive and supportive school climate can enhance teachers' sense of belonging and security, as well as inspire their teaching enthusiasm and professional commitment. Additionally, collective innovation among teachers has been shown to significantly improve job satisfaction by promoting knowledge sharing and professional growth (Dicke et al., 2020; Liu et al., 2021; Toropova et al., 2021). Therefore, it is hypothesized that the educational context contributes to shaping teachers' job satisfaction.

Based on an extensive review of existing literature, it is clear that a substantial link exists in relation to school climate and teachers' job satisfaction. Taking this into account, current research constructs a theoretical framework comprising three distinct elements within the school climate (teacher-student relationship, culture of collaboration, working atmosphere) as independent variables. Mediating the connection between these factors is the notion of collective innovativeness, with teachers' job satisfaction being the dependent variable. The interrelationships among the variables in the theoretical framework are illustrated in Figure 1.

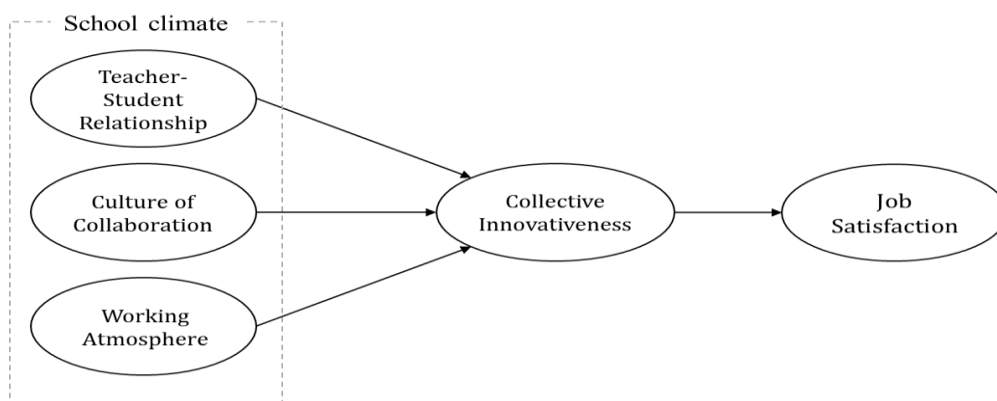

Figure 1. Research Model

## Methodology

### Data Collection and Sampling

This paper used TALIS 2018 examination report, associated data that were published by OECD. This paper conducted an in-depth analysis of the Shanghai sample, which consisted of responses from 3,976 teachers. The basic information of the

sample is as follows: (a) Gender composition: female Proportion of sex teachers 74%, male proportion 26%; (b) Age composition: The age distribution showed a spindle shape, and the proportion of teachers under 25 was 3.0%, 25-29 was 13.4%, 30-39 was 33.1%, 40-49 was 35.7%, 50-59 was 14.2%, over 60 was 14.2%; (c) Education level: The bachelor degree accounted for the majority with 86.1%, followed by master's degrees with 13.0%. Teacher demographic information is presented in Table 1.

Table 1. Demographics

Characteristic		Sample (N)	Percentage (%)
Gender	Male	1,035	26.0
	Female	2,941	74.0
Age	Under 25	119	3.0
	25-29	534	13.4
	30-39	1,316	33.1
	40-49	1,418	35.7
	50-59	566	14.2
	60 and above	22	0.6
Education level	Short tertiary education	35	0.9
	Bachelor	3,413	86.1
	Master or higher	514	13.0
Total		3,976	100

### Research Procedures

This study utilized the following research procedures and methodologies to analyze the survey data that was collected.

Initially, SPSS 26.0 program was utilized to examine the reliability, Exploratory Factor Analysis (EFA), frequency distribution, and correlation of the collected data. Subsequently, AMOS 26.0 program was used to conduct Confirmatory Factor Analysis (CFA) and evaluate convergent validity. Specifically, the alpha-test assessed the survey instrument's internal consistency reliability. EFA and CFA were conducted to validate the measurement model and ensure that the survey instrument is measuring the intended constructs. Descriptive statistics were conducted to describe the sample and examine the correlations between variables.

Finally, SEM was employed to assess the proposed research model, examining direct and indirect effects among variables. Structural Equation Modeling (SEM) integrates a range of statistical analysis techniques, allowing for the simultaneous examination of relationships between multiple factors and analysis variables and can measure the fit of the overall model, is a non-experimental method to obtain causality, and by examining the external performance of people to understand their substantive characteristics (potential variables or psychological concepts) technology. This study followed Gerbing and Anderson's (1988) recommended two-stage SEM process. First, we assessed the measurement model's fit, then we examined the structural model to validate the theoretical framework and assess the influence mechanism.

## Results

### Correlation and Descriptive Statistics

Table 2 displays descriptive statistics, including means, standard deviations, skewness, kurtosis, and correlations for all research variables. The mean values ranged from 2.910 to 3.404, standard deviations ranging from .485 to .996. Additionally, we examined variable normality with through Skewness and Kurtosis measurements, and all variables exhibited Skewness < 2 and Kurtosis < 7. As a result, we concluded that all variables followed a multivariate normal distribution and were suitable for SEM analysis (Hu & Bentler, 1999).

The correlation coefficient between the five variables ranged from .252 to .601 ( $p < .001$ ), indicating a significant positive correlation. Significantly, a strong positive correlation was evident between Teacher-Student Relationship and Working Atmosphere ( $r = .601$ ). Conversely, the weakest correlation was found between Culture of Collaboration and Collective Innovativeness ( $r = .252$ ).

Table 2. Correlation and Descriptive Statistics

	TS	CC	WA	JS	CI
CC	.316***				
WA	.601***	.334***			
JS	.484***	.305***	.465***		
CI	.433***	.252***	.495***	.360***	
Mean	3.346	3.404	3.052	3.172	2.910
SD	0.485	0.996	0.587	0.597	0.514
Skewness	-0.101	0.358	-0.385	-0.586	-0.068
Kurtosis	0.324	-0.094	1.287	1.574	0.938

Notes: \*\*\* $p < .001$ . TS=Teacher-Student Relationship; CC=Culture of Collaboration; WA=Working Atmosphere; JS=Job Satisfaction; CI=Collective Innovativeness.

### Measurement Model

Firstly, we evaluated the measurement model's construct reliability and convergent validity, employing CR, AVE, and Cronbach's alpha to assess construct reliability. The values of CR ranged from .812 to .928 (above .70). The AVE values ranged from .520 to .763 (above .5). All variables exhibited Cronbach's alpha values within the range of .720 to .949, which were above the suggested value of .70.

Table 3. Measurement of Constructs

Variables	Items	Loadings	Cronbach's a	CR	AVE
Teacher-Student Relationship	TS1	.817	.928	.900	.643
	TS2	.849			
	TS3	.838			
	TS4	.747			
	TS5	.755			
Culture of Collaboration	CC1	.722	.720	.812	.520
	CC2	.710			
	CC3	.779			
	CC4	.670			
Working Atmosphere	WA1	.821	.932	.900	.645
	WA2	.821			
	WA3	.755			
	WA4	.821			
	WA5	.796			
Collective Innovativeness	CI1	.866	.949	.928	.763
	CI2	.874			
	CI3	.893			
	CI4	.862			
Job Satisfaction	JB1	.728	.825	.848	.528
	JB2	.785			
	JB3	.674			
	JB4	.702			
	JB5	.741			

The measurement model in this study is given in Figure 2. The fit of the measurement model was verified. Model fit indicators are employed to determine whether the empirical data conform to the theoretical structural equation model. The results revealed a good structural model fit with CFI = .963, TLI = .958, and RMSEA = .052. The value of model fit indicators in this study has met the recommended thresholds, indicating a significant fit for the measurement model.

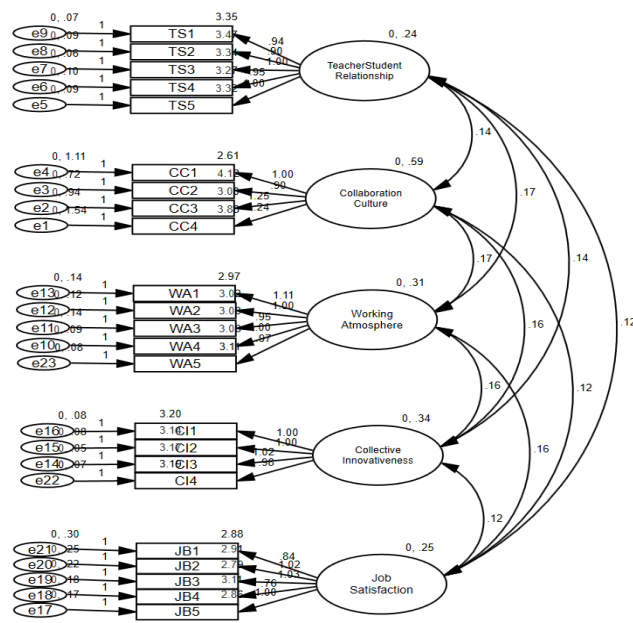

Figure 2. Measurement Model

Research Model

The structural model was verified to better understand the relationship between Teacher-Student Relationship, Culture of Collaboration, Working Atmosphere, Collective Innovativeness, and Job Satisfaction. Figure 3 displays the findings. The research results revealed a good structural model fit with CFI = .951, TLI = .945, IFI = .951, NFI = .948, and RMSEA = .059. As a result, the proposed model suited the empirical data well.

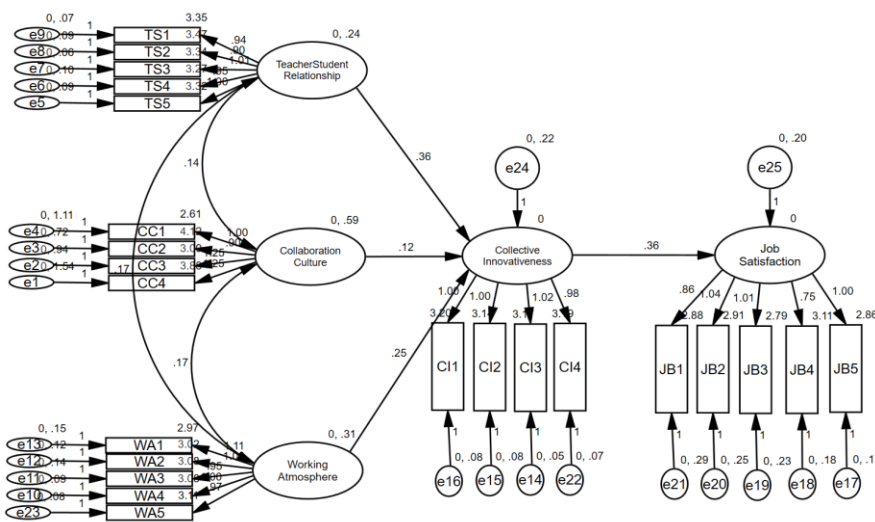

Figure 3. Research Model

Hypothesis Test

Furthermore, Table 3 showed that the four proposed relationships, and the structural model were significant in the predicted direction. The path coefficients of the research model were analyzed and all of the suggested hypotheses were accepted.

According to the data, all regression paths of the research model in this study are significant ( $p < .001$ ). Teacher-Student Relationship ( $\beta = .306$ ), Culture of Collaboration ( $\beta = .154$ ), Working Atmosphere ( $\beta = .238$ ) all have positive effect on Collective Innovativeness. Meanwhile, Collective Innovativeness positively impacts significantly on Job Satisfaction ( $\beta = .419$ ). In particular, Collective Innovativeness to Job Satisfaction has the highest value of all paths.

Table 4. Results of the Hypothesis Test

Path			B	$\beta$	S.E.	C.R.
Teacher-Student Relationship	→	Collective Innovativeness	.365	.306	.024	15.390***
Culture of Collaboration	→	Collective Innovativeness	.116	.154	.014	8.276***

Working Atmosphere	→	Collective Innovativeness	.248	.238	.021	11.879***
Collective Innovativeness	→	Job Satisfaction	.360	.419	.015	23.659***

Notes: \*\*\* $p < .001$ .

### Mediating Effects of Bootstrapping

This study employed bootstrapping with a sample size of 5,000 to assess the significance of the mediating effect. To gain a better understanding of the model assumptions' verification results, we summarized the structural relationship between latent variables and estimated standardized path coefficients in Table 4.

Based on our findings, Collective Innovativeness was found to mediate between School Climate and Job Satisfaction. Specifically, Collective Innovativeness exhibited a notably positive indirect impact (.035) on Teacher-Student Relationship and Job Satisfaction. Additionally, it had a notable indirect positive impact (.011) on Culture of Collaboration and Job Satisfaction. Moreover, it showed a substantial and positive indirect influence (.023) on Working Atmosphere and Job Satisfaction.

Table 5. Mediating Effects of Bootstrapping

Path	Estimate	S.E.	Bootstrap 5000 times 95% CI Bias-corrected	
			Lower	Upper
TS → CI → JS	.035	.007	.108	.150
CC → CI → JS	.011	.003	.050	.081
WA → CI → JS	.023	.005	.079	.122

Notes: TS=Teacher-Student Relationship; CC=Culture of Collaboration; WA=Working Atmosphere; CI=Collective Innovativeness; JS=Job Satisfaction.

### Discussion

This study discussed that collective innovativeness completely mediated the relation between school climate and teachers' job satisfaction. The more positive the school climate is, the more teachers are satisfied with their job as their innovativeness is strengthened.

This result is relevant to discussions of Aldridge and Fraser (2016), Aldrup et al. (2018), Collie et al. (2011), Dou et al. (2017), Ghavifekr and Pillai (2016) and Mu et al. (2016). These studies have indicated a favorable link between the environment within schools and teachers' job satisfaction. Particularly notable is factor such as teacher-student interactions, which has been associated with teachers' contentment in their profession. In this study, Teacher-Student Relationship, ( $\beta = .306, p < .001$ ) among the school climate was demonstrated as a variable that had the greatest influence on teachers' job satisfaction. In a broader sense, Hargreaves (2000) reported higher levels of satisfaction when they received support from school administrators and colleagues, had increased opportunities for collective participation in school-level decisions, and cultivated positive relationships with their students. From a theoretical perspective on psychological interaction, positive interactions between teachers and students may be one of the most significant factors to overcome the bureaucratic organizational pattern of secondary schools.

In addition, the results of this study confirmed that the collaboration culture and working atmosphere of schools are a prerequisite for reinforcing the collective innovativeness of teachers. Relatedly, Dou et al. (2017) also emphasized the potential influence of the school climate. Therefore significant influence of a comprehensive and emotional atmosphere on both students and teachers should be actively considered at a practical level. In particular, it is necessary to prioritize practical support for teachers' innovativeness activities to develop transformational competence required for students in the global future society.

Moreover, we focused on a community sense that supports each other among teachers (item of collective innovativeness (CI)-4). It was demonstrated that the teacher's Collective Innovativeness is a relatively low level of personal characteristics (Mean=2.910) and a strong mediating variable ( $\beta = .419, p < .001$ ) for job satisfaction improvement. This result show that collective innovativeness acts as a decisive causal mechanism for teachers' job satisfaction, at the same time, it is a capacity that requires improvement. Blömeke et al. (2021) also substantiated the notion that teachers' collective innovativeness not only exhibits a favorable connection with individual-level teachers' job satisfaction but also correlates positively with teachers' satisfaction within the broader school context. People who live in a collectivist culture, including Asia, and have to constantly interact with others at work can pursue innovation and be satisfied with their professional situation in a supportive interpersonal environment (Cai & Tang, 2022). This study suggests what kind of effort the school should make from the point of view of communitarianism while recognizing the teacher as the totality of personality.

### Conclusion

The main aim of the study was to investigate the intermediary function of collective innovativeness within the dynamic of school climate and teachers' contentment in their profession. By examining how collective innovativeness operates as



a mediator in these relationships, the research contributed to revealing the structural mechanisms that establish a connection between the overall school environment and teachers' contentment in their roles.

The majority of teachers need to derive contentment from their roles, rendering teaching an esteemed and aspirational profession in Chinese society (Ministry of Education of the People's Republic of China, 2018). The current research sheds light on the job satisfaction issues faced by teachers teaching in secondary schools across China (Y. Lin, 2020). This issue contributes to inadequate dedication to teaching tasks and an elevated rate of turnover, posing considerable challenges to the stability and advancement of teaching professionals (P. Zhang & Xu, 2021; W. Zhang et al., 2023). Based on an examination of the 2015 PISA dataset (OECD, 2019b), Chinese teachers expressed lower contentment with both their professional roles and the educational setting compared to the average satisfaction levels reported by teachers in OECD countries. The low job satisfaction of teachers will lead to insufficient investment in teachers' work, a high staff turnover rate, and the stability and development of teachers are facing great challenges.

Our research results proved that in order to improve teachers' job satisfaction, it is inevitable to create a cooperative climate at the organizational level and strengthen collective innovativeness at the individual level. This is because the satisfaction of psychological needs is achieved by the interaction between individuals and their environments (Cai & Tang, 2022). Therefore, collaborative engagement among teacher colleagues, requires the level of involvement teachers have in joint initiatives, the exchange of ideas, and mutual support for each other's growth in the professional sphere. In addition, it involves a collaborative approach to problem-solving, joint planning, and the exchange of instructional strategies. A high level of innovative cooperation among colleagues contributes to a positive working atmosphere and can lead to improved teaching practices and job satisfaction.

### Recommendations

Building upon research results, we underscore the pivotal role that school climate plays in nurturing teacher innovativeness. Additionally, it affirms the favorable connection between school climate and teachers' innovative behaviors and satisfactory outcomes.

Therefore, schools should strive to create a cooperative and relationship-oriented school climate. In particular, this study emphasized the co-agency in which teachers and students can pioneer life in cooperation with each other. This is because teachers and students should be able to reveal their identities while pursuing personal and social well-being in an era of deepening uncertainty, such as the advent of the fourth industrial revolution and changes in the climate environment.

Next, efforts are needed to support teachers in executing active and collaborative actions to create new values. Job satisfaction enables teachers to demonstrate their professionalism effectively over a long period time and better supports students' achievements. This study verified that collective innovativeness is a strong predictor of job satisfaction. Developing teachers' innovativeness plays a positive role in maintaining positive emotions not only for students but also for teachers themselves. Therefore, it is necessary to design goal-oriented training and learning community activities so that teachers can build collective innovativeness.

In addition, a process of exploring the effect of teachers' collective innovativeness on students' competency growth is required as future research. For instance, this study recommend research to demonstrate whether teachers' collective innovativeness contributes to students' ability to create new values. In this study, the importance of a collective environment was discussed with a focus on teachers, nevertheless, students are the key element for school innovativeness, so future studies need to explore student growth progress.

### Limitations

Nevertheless, this study has a limitation in not considering the premise that the influence relationship can also change as the characteristics of teachers, such as collective innovativeness and job satisfaction, change or grow. Therefore, we can propose a follow-up study on whether job satisfaction changes according to changes in teacher innovativeness over time. In order to compensate for these limitations, the search for changes in collective innovativeness should be preceded.

### Authorship Contribution Statement

Hu: Conceptualization, design, data acquisition, data analysis and interpretation, drafting manuscript, writing. Park: Critical revision of manuscript, writing, supervision. Xu: Drafting manuscript, investigation, writing, technical or material support.

### References

- Aldridge, J. M., & Fraser, B. J. (2016). Teachers' views of their school climate and its relationship with teacher self-efficacy and job satisfaction. *Learning Environments Research*, 19, 291-307. <https://doi.org/10.1007/s10984-015-9198-x>
- Aldrup, K., Carstensen, B., & Klusmann, U. (2022). Is empathy the key to effective teaching? A systematic review of its association with teacher-student interactions and student outcomes. *Educational Psychology Review*, 34, 1177-1216. <https://doi.org/10.1007/s10648-021-09649-y>

- Aldrup, K., Klusmann, U., Lüdtke, O., Göllner, R., & Trautwein, U. (2018). Student misbehavior and teacher well-being: Testing the mediating role of the teacher-student relationship. *Learning and Instruction, 58*, 126-136. <https://doi.org/10.1016/j.learninstruc.2018.05.006>
- Banerjee, N., Stearns, E., Moller, S., & Mickelson, R. A. (2017). Teacher job satisfaction and student achievement: The roles of teacher professional community and teacher collaboration in schools. *American Journal of Education, 123*(2), 203-341. <https://doi.org/10.1086/689932>
- Blömeke, S., Nilsen, T., & Scherer, R. (2021). School innovativeness is associated with enhanced teacher collaboration, innovative classroom practices, and job satisfaction. *Journal of Educational Psychology, 113*(8), 1645-1667. <https://doi.org/10.1037/edu0000668>
- Bogler, R. (2001). The influence of leadership style on teacher job satisfaction. *Educational Administration Quarterly, 37*(5), 662-683. <https://doi.org/10.1177/00131610121969460>
- Borko, H. (2004). Professional development and teacher learning: Mapping the terrain. *Educational Researcher, 33*(8), 3-15. <https://doi.org/10.3102/0013189X033008003>
- Burić, I., & Moè, A. (2020). What makes teachers enthusiastic: The interplay of positive affect, self-efficacy and job satisfaction. *Teaching and Teacher Education, 89*, Article 103008. <https://doi.org/10.1016/j.tate.2019.103008>
- Buyse, E., Verschueren, K., Doumen, S., Van Damme, J., & Maes, F. (2008). Classroom problem behavior and teacher-child relationships in kindergarten: The moderating role of classroom climate. *Journal of School Psychology, 46*(4), 367-391. <https://doi.org/10.1016/j.jsp.2007.06.009>
- Buyukgoze, H., Caliskan, O., & Gümüş, S. (2022). Linking distributed leadership with collective teacher innovativeness: The mediating roles of job satisfaction and professional collaboration. *Educational Management Administration and Leadership*. Advance online publishing. <https://doi.org/10.1177/17411432221130879>
- Cai, Y., & Tang, R. (2022). School support for teacher innovation: The role of basic psychological need satisfaction. *Thinking Skills and Creativity, 45*, Article 101096. <https://doi.org/10.1016/j.tsc.2022.101096>
- Caprara, G. V., Barbaranelli, C., Steca, P., & Malone, P. S. (2006). Teachers' self-efficacy beliefs as determinants of job satisfaction and students' academic achievement: A study at the school level. *Journal of School Psychology, 44*(6), 473-490. <https://doi.org/10.1016/j.jsp.2006.09.001>
- Coleman, J. S. (1966). *Equality of educational opportunity (COLEMAN) Study (EEOS), 1966*. Inter-university Consortium for Political and Social Research. <https://doi.org/10.3886/ICPSR06389.v3>
- Collie, R. J., Shapka, J. D., & Perry, N. E. (2011). Predicting teacher commitment: The impact of school climate and social-emotional learning. *Psychology in the Schools, 48*(10), 1034-1048. <https://doi.org/10.1002/pits.20611>
- Creemers, B. P. M. (1999). The role of school and classroom climate in elementary school learning environments. In H. J. Freiberg (Ed.), *School Climate: Measuring, Improving and Sustaining Healthy Learning Environments* (pp. 30-47). Routledge.
- Darling-Hammond, L. (2000). Teacher quality and student achievement. *Education Policy Analysis Archives, 8*(1), 1-44. <https://doi.org/10.14507/epaa.v8n1.2000>
- Dicke, T., Marsh, H. W., Parker, P. D., Guo, J., Riley, P., & Waldeyer, J. (2020). Job satisfaction of teachers and their principals in relation to climate and student achievement. *Journal of Educational Psychology, 112*(5), 1061-1073. <https://doi.org/10.1037/edu0000409>
- Dinc, M. S., & Kocyigit, Z. (2017). Do job satisfaction and demographic characteristics of female teachers influence their affective commitment to schools? *European Journal of Educational Research, 6*(4), 475-484. <https://doi.org/10.12973/eu-jer.6.4.475>
- Dinham, S. (1995). Time to focus on teacher satisfaction. *Unicorn, 21*(3), 64-75.
- Djonko-Moore, C. M. (2016). An exploration of teacher attrition and mobility in high poverty racially segregated schools. *Race Ethnicity and Education, 19*(5), 1063-1087. <https://doi.org/10.1080/13613324.2015.1013458>
- Domínguez, X., Vitiello, V. E., Fuccillo, J. M., Greenfield, D. B., & Bulotsky-Shearer, R. J. (2011). The role of context in preschool learning: A multilevel examination of the contribution of context-specific problem behaviors and classroom process quality to low-income children's approaches to learning. *Journal of School Psychology, 49*(2), 175-195. <https://doi.org/10.1016/j.jsp.2010.11.002>
- Dou, D., Devos, G., & Valcke, M. (2017). The relationships between school autonomy gap, principal leadership, teachers' job satisfaction and organizational commitment. *Educational Management Administration and Leadership, 45*(6), 959-977. <https://doi.org/10.1177/1741143216653975>

- Fullan, M. (2015). *The New Meaning of Educational Change*. Teachers College Press.
- Gerbing, D. W., & Anderson, J. C. (1988). An updated paradigm for scale development incorporating unidimensionality and its assessment. *Journal of Marketing Research*, 25(2), 186-192. <https://doi.org/10.1177/002224378802500207>
- Ghavifekr, S., & Pillai, N. S. (2016). The relationship between school's organizational climate and teacher's job satisfaction: Malaysian experience. *Asia Pacific Education Review*, 17, 87-106. <https://doi.org/10.1007/s12564-015-9411-8>
- Gkorezis, P. (2016). Principal empowering leadership and teacher innovative behavior: a moderated mediation model. *International Journal of Educational Management*, 30(6), 1030-1044. <https://doi.org/10.1108/IJEM-08-2015-0113>
- Gokalp, S. (2022). The relationship between school principals' cultural intelligence level and teachers' job satisfaction and intention to leave the job. *European Journal of Educational Research*, 11(1), 493-509. <https://doi.org/10.12973/eu-jer.11.1.493>
- Goldsmith, R. E. (1986). Convergent validity of four innovativeness scales. *Educational and Psychological Measurement*, 46(1), 81-87. <https://doi.org/10.1177/0013164486461007>
- Hamre, B. K., Pianta, R. C., Downer, J. T., & Mashburn, A. J. (2008). Teachers' perceptions of conflict with young students: Looking beyond problem behaviors. *Social Development*, 17(1), 115-136. <https://doi.org/10.1111/j.1467-9507.2007.00418.x>
- Hargreaves, A. (2000). Mixed emotions: Teachers' perceptions of their interactions with students. *Teaching and Teacher Education*, 16(8), 811-826. [https://doi.org/10.1016/S0742-051X\(00\)00028-7](https://doi.org/10.1016/S0742-051X(00)00028-7)
- Herzberg, F. (1993). *Motivation to Work* (1st ed.). Routledge. <https://doi.org/10.4324/9781315124827>
- Hoque, K. E., Wang, X., Qi, Y., & Norzan, N. (2023). The factors associated with teachers' job satisfaction and their impacts on students' achievement: a review (2010–2021). *Humanities and Social Sciences Communications*, 10, Article 177. <https://doi.org/10.1057/s41599-023-01645-7>
- Hosford, S., & O'Sullivan, S. (2016). A climate for self-efficacy: the relationship between school climate and teacher efficacy for inclusion. *International Journal of Inclusive Education*, 20(6), 604-621. <https://doi.org/10.1080/13603116.2015.1102339>
- Hu, L.-T., & Bentler, P. M. (1999). Cutoff criteria for fit indexes in covariance structure analysis: Conventional criteria versus new alternatives. *Structural Equation Modeling: a Multidisciplinary Journal*, 6(1), 1-55. <https://doi.org/10.1080/10705519909540118>
- Izaguirre, L. A., Rodríguez-Fernández, A., & Fernández-Zabala, A. (2023). Perceived academic performance explained by school climate, positive psychological variables and life satisfaction. *British Journal of Educational Psychology*, 93(1), 318-332. <https://doi.org/10.1111/bjep.12557>
- Judge, T. A., Thoresen, C. J., Bono, J. E., & Patton, G. K. (2001). The job satisfaction–job performance relationship: a qualitative and quantitative review. *Psychological Bulletin*, 127(3), 376-407. <https://doi.org/10.1037/0033-2909.127.3.376>
- Kemmis, S., Wilkinson, J., Edwards-Groves, C., Hardy, I., Grootenboer, P., & Bristol, L. (2013). Praxis, practice and practice architectures. In S. Kemmis & L. Bristol (Eds.), *Changing Practices, Changing Education* (pp. 25-41). Springer. [https://doi.org/10.1007/978-981-4560-47-4\\_2](https://doi.org/10.1007/978-981-4560-47-4_2)
- Khan, N. (2019). The impact of organizational climate on teachers commitment. *Journal of education and educational development*, 6(2), 327-342. <https://files.eric.ed.gov/fulltext/EJ1235085.pdf>
- Laybourn, S., Frenzel, A. C., & Fenzl, T. (2019). Teacher procrastination, emotions, and stress: A qualitative study. *Frontiers in Psychology*, 10, Article 2325. <https://doi.org/10.3389/fpsyg.2019.02325>
- Lin, Q. (2022). The relationship between distributed leadership and teacher innovativeness: Mediating roles of teacher autonomy and professional collaboration. *Frontiers in Psychology*, 13, Article 948152. <https://doi.org/10.3389/fpsyg.2022.948152>
- Lin, Y. (2020). 积极性对工作满意度的影响：一个调节中介模型 [The effects of proactive personality on job satisfaction: A moderated mediation model]. *Psychological Development and Education*, 36(1), 103-112. <https://doi.org/10.16187/j.cnki.issn1001-4918.2020.01.12>
- Lipscombe, K., Buckley-Walker, K., & McNamara, P. (2020). Understanding collaborative teacher teams as open systems for professional development. *Professional Development in Education*, 46(3), 373-390. <https://doi.org/10.1080/19415257.2019.1613256>

- Liu, Y., Bellibaş, M. Ş., & Gümüş, S. (2021). The effect of instructional leadership and distributed leadership on teacher self-efficacy and job satisfaction: Mediating roles of supportive school culture and teacher collaboration. *Educational Management Administration and Leadership*, 49(3), 430-453. <https://doi.org/10.1177/1741143220910438>
- Mailool, J., Kartowagiran, B., Retnowati, T. H., Wening, S., & Putranta, H. (2020). The effects of principal's decision-making, organizational commitment and school climate on teacher performance in vocational high school based on teacher perceptions. *European Journal of Educational Research*, 9(4), 1675-1687. <https://doi.org/10.12973/eu-jer.9.4.1675>
- Mayes, E., Wolfe, M. J., & Higham, I. (2020). Re/imagining school climate: Towards processual accounts of affective ecologies of schooling. *Emotion, Space and Society*, 36, Article 100703. <https://doi.org/10.1016/j.emospa.2020.100703>
- McGeown, V. (1979). School innovativeness as process and product. *British Educational Research Journal*, 5(2), 221-235. <https://doi.org/10.1080/0141192790050208>
- McGeown, V. (1980). Dimensions of teacher innovativeness. *British Educational Research Journal*, 6(2), 147-163. <https://doi.org/10.1080/0141192800060204>
- Meristo, M., & Eisenschmidt, E. (2014). Novice teachers' perceptions of school climate and self-efficacy. *International Journal of Educational Research*, 67, 1-10. <https://doi.org/10.1016/j.ijer.2014.04.003>
- Ministry of Education of the People's Republic of China. (2018). 中共中央国务院关于全面深化新时代教师队伍建设改革的意见 [Opinions of the central committee of the communist party of china and the state council on comprehensively deepening the reform of the construction of teacher team in the new era]. <https://bit.ly/3QnDcu9>
- Moolenaar, N. M., Daly, A. J., Cornelissen, F., Liou, Y.-H., Caillier, S., Riordan, R., Wilson, K., & Cohen, N. A. (2014). Linked to innovation: Shaping an innovative climate through network intentionality and educators' social network position. *Journal of Educational Change*, 15, 99-123. <https://doi.org/10.1007/s10833-014-9230-4>
- Mu, H., Hu, Y., & Liu, H. (2016). 中学教师工作满意度及其影响因素研究 [Study of Chinese secondary school teachers' job satisfaction and the influential factors]. *Journal of Educational Studies*, 12(2), 71-80. <https://doi.org/10.14082/j.cnki.1673-1298.2016.02.009>
- Nguyen, D., Pietsch, M., & Gümüş, S. (2021). Collective teacher innovativeness in 48 countries: effects of teacher autonomy, collaborative culture, and professional learning. *Teaching and Teacher Education*, 106, Article 103463. <https://doi.org/10.1016/j.tate.2021.103463>
- Organisation for Economic Co-operation and Development. (2019a). *OECD future of education and skills 2030: OECD learning compass 2030*. <https://bit.ly/49UJM21>
- Organisation for Economic Co-operation and Development. (2019b). *TALIS 2018 Technical Report*. OECD Publications. <https://bit.ly/4dhr1ZH>
- Reyes, P., & Shin, H.-S. (1995). Teacher commitment and job satisfaction: A causal analysis. *Journal of School Leadership*, 5(1), 22-39. <https://doi.org/10.1177/105268469500500102>
- Rossmiller, R. A. (1992). The secondary school principal and teachers' quality of work life. *Educational Management and Administration*, 20(3), 132-146. <https://doi.org/10.1177/174114329202000302>
- Ryan, R. M., & Deci, E. L. (2000). Self-determination theory and the facilitation of intrinsic motivation, social development, and well-being. *American Psychologist*, 55(1), 68-78. <https://doi.org/10.1037/0003-066X.55.1.68>
- Şahin, F., & Tabak, H. (2020). Investigation of school administrators' humour styles and school climate according to teacher perceptions. *Acta Educationis Generalis*, 10(3), 34-49. <https://doi.org/10.2478/atd-2020-0019>
- Schaufeli, W. B., & Salanova, M. (2007). Efficacy or inefficacy, that's the question: Burnout and work engagement, and their relationships with efficacy beliefs. *Anxiety, Stress, and Coping*, 20(2), 177-196. <https://doi.org/10.1080/10615800701217878>
- Schwabsky, N., Erdogan, U., & Tschannen-Moran, M. (2020). Predicting school innovation: The role of collective efficacy and academic press mediated by faculty trust. *Journal of Educational Administration*, 58(2), 246-262. <https://doi.org/10.1108/JEA-02-2019-0029>
- Skaalvik, E. M., & Skaalvik, S. (2010). Teacher self-efficacy and teacher burnout: A study of relations. *Teaching and Teacher Education*, 26(4), 1059-1069. <https://doi.org/10.1016/j.tate.2009.11.001>
- Sukarmin, S., & Sin, I. (2021). School health as the mediator variable: determinants of the principal instructional leadership behavior. *European Journal of Educational Research*, 10(3), 1275-1286. <https://doi.org/10.12973/eu-jer.10.3.1275>

- Tang, Y. (2021). Does information and communication technology (ICT) empower teacher innovativeness: a multilevel, multisite analysis. *Educational Technology Research and Development*, 69, 3009-3028. <https://doi.org/10.1007/s11423-021-10052-1>
- Thurlings, M., Evers, A. T., & Vermeulen, M. (2015). Toward a model of explaining teachers' innovative behavior: A literature review. *Review of Educational Research*, 85(3), 430-471. <https://doi.org/10.3102/0034654314557949>
- Toropova, A., Myrberg, E., & Johansson, S. (2021). Teacher job satisfaction: the importance of school working conditions and teacher characteristics. *Educational Review*, 73(1), 71-97. <https://doi.org/10.1080/00131911.2019.1705247>
- Uwannah, N. C., Egwuonwu, C. O. K., & James, N. C. (2022). Job autonomy, workload and home-work conflict as predictors of job satisfaction among employed women in academia. *European Journal of Educational Management*, 5(1), 35-48. <https://doi.org/10.12973/eujem.5.1.35>
- Wanders, F. H. K., Dijkstra, A. B., Maslowski, R., & Van der Veen, I. (2020). The effect of teacher-student and student-student relationships on the societal involvement of students. *Research Papers in Education*, 35(3), 266-286. <https://doi.org/10.1080/02671522.2019.1568529>
- Wang, M.-T., & Degol, J. L. (2016). School climate: A review of the construct, measurement, and impact on student outcomes. *Educational Psychology Review*, 28, 315-352. <https://doi.org/10.1007/s10648-015-9319-1>
- Weiqi, C. (2007). The structure of secondary school teacher job satisfaction and its relationship with attrition and work enthusiasm. *Chinese Education and Society*, 40(5), 17-31. <https://doi.org/10.2753/CED1061-1932400503>
- Wentzel, K. R. (2016). Teacher-student relationships. In K. R. Wentzel & D. B. Miele (Eds.), *Handbook of Motivation at School* (2nd ed., pp. 211-230). Routledge. <https://doi.org/10.4324/9781315773384>
- Yang, C., Chan, M.-K., Lin, X., & Chen, C. (2022). Teacher victimization and teacher burnout: Multilevel moderating role of school climate in a large-scale survey study. *Journal of School Violence*, 21(2), 206-221. <https://doi.org/10.1080/15388220.2022.2041023>
- Zhang, P., & Xu, J. (2021). 差异与逃避：高质量青年人才在县域的流动性质性研究——以高等教育背景下年轻教师的辞职为例 [Discrepancy and escape: A qualitative study on the mobility of high-quality young talents in county areas - Taking the resignation of young teachers with higher education as an example]. *中国青年研究 [China Youth Study]*, (07), 5-14. <https://doi.org/10.19633/j.cnki.11-2579/d.2021.0097>
- Zhang, W., He, E., Mao, Y., Pang, S., & Tian, J. (2023). How teacher social-emotional competence affects job burnout: The chain mediation role of teacher-student relationship and well-being. *Sustainability*, 15(3), Article 2061. <https://doi.org/10.3390/su15032061>